



Centrifugal Fire Pumps Split-Case Type

300~8000 GPM 50~570 PSI 32 Models (UL448/FM1311)

NFPA20标准消防泵系统(一电、一柴、一稳压)
NFPA20 Standard Fire Pump Package System
(1 Electric Motor Unit & 1 Diesel Engine Unit & Jockey Pump Unit.)



卧式中开离心式消防泵
Centrifugal Fire Pumps, Horizontal Split-Case Type

UL/FM系列型号 UL/FM Model

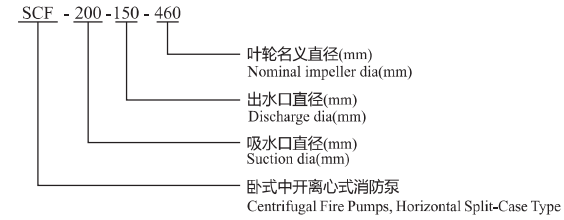

GB系列型号 GB Model

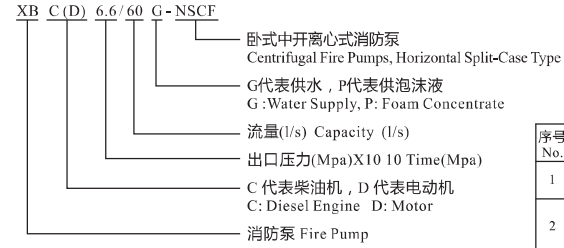

结构图 Structure Design

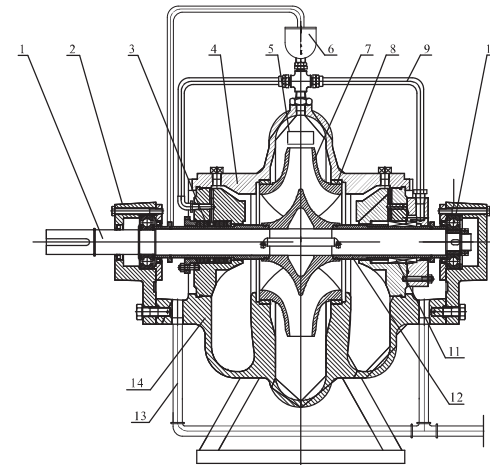

序号 No.	零 / 部件名称 Name	材质 Material
1	主轴 Shaft	20Cr13
2	轴承体 Bearing Housing(DE)	铸铁 Cast Iron
3	填料密封部 Packing Seal Assembly	
4	泵盖 Upper casing	铸铁 / 球铁 / 铸钢 Cast Iron/Ductile Cast Iron/Cast Steel
5	铭牌 Nameplate	不锈钢 Stainless Steel
6	自动排气阀 Air Release Valve	
7	叶轮 Impeller	不锈钢 / 铜 Stainless Steel/Bronze
8	泵体密封环 Casing Seal Ring	不锈钢 / 铜 Stainless Steel/Bronze
9	冲洗管路 Flushing Pipe	碳钢 / 不锈钢 Carbon Steel/ Stainless Steel
10	轴承 Bearing	SKF
11	机械密封部 Mechanical Seal Assembly	
12	轴套 Shaft Sleeve	不锈钢 Stainless Steel
13	排液管路 Drainage Pipe	碳钢 Carbon Steel
14	泵体 Pump Casing	铸铁 / 球铁 / 铸钢 Cast Iron/Ductile Cast Iron/Cast Steel

卧式中开离心式消防泵
Centrifugal Fire Pumps, Horizontal Split-Case Type

UL/FM(SCF)系列卧式中开泵性能范围
UL/FM(SCF) Performance Range Of Horizontal Split-Case Type

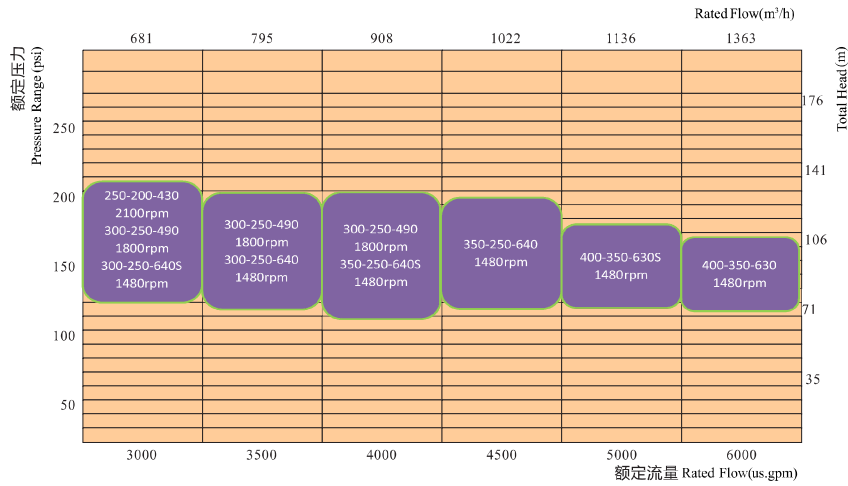
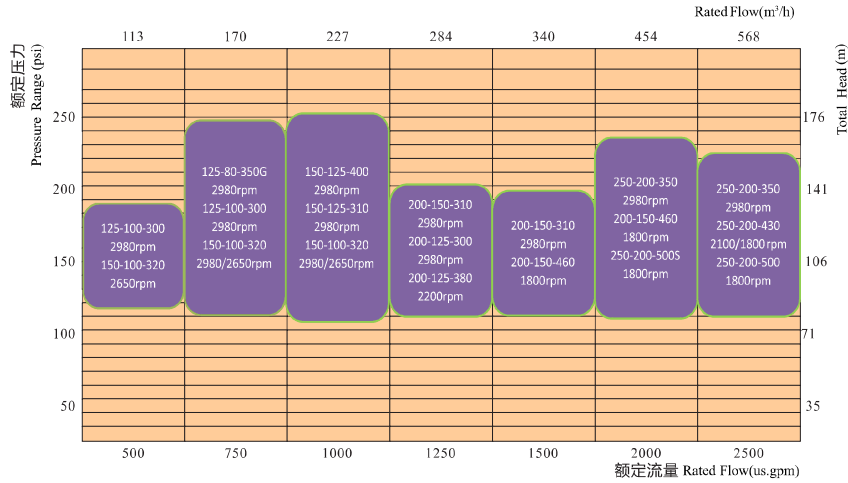

卧式中开离心式消防泵
Centrifugal Fire Pumps, Horizontal Split-Case Type

GB(NSCF)系列卧式中开泵性能范围
GB(NSCF) Performance Range Of Horizontal Split-Case Type

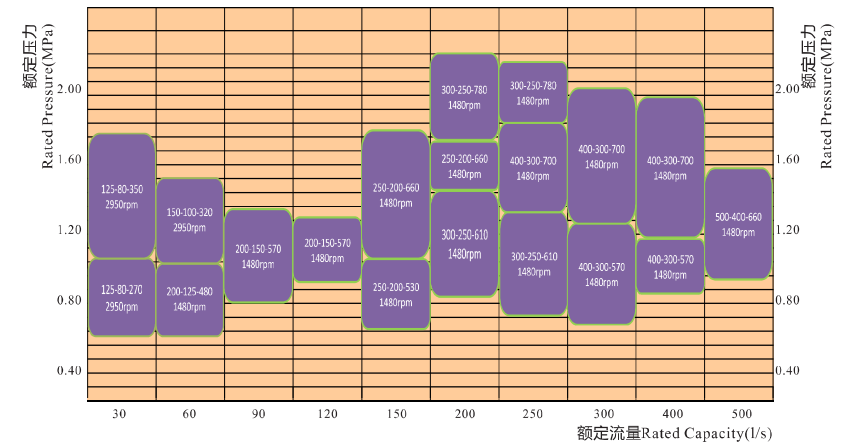
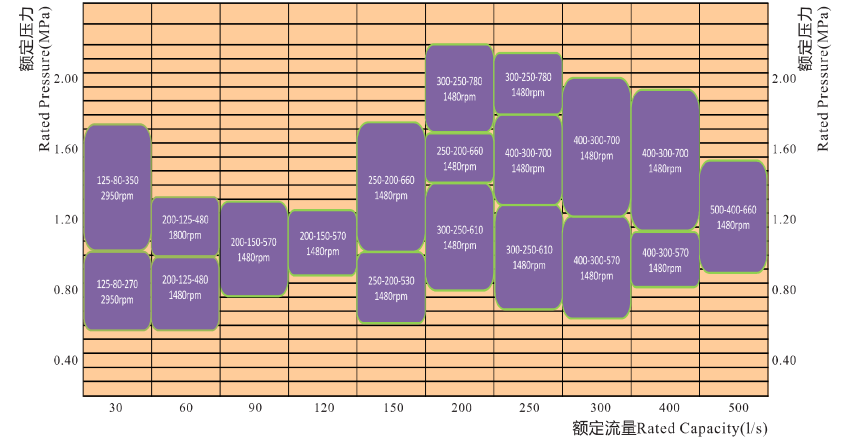

卧式端吸离心式消防泵组
Centrifugal Fire Pumps, Horizontal End-Suction Type

UL/FM系列型号 UL/FM Model

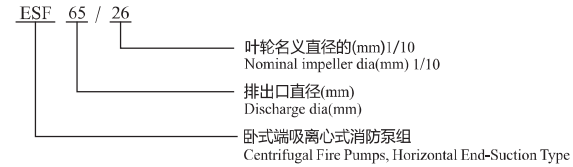

GB系列型号 GB Model

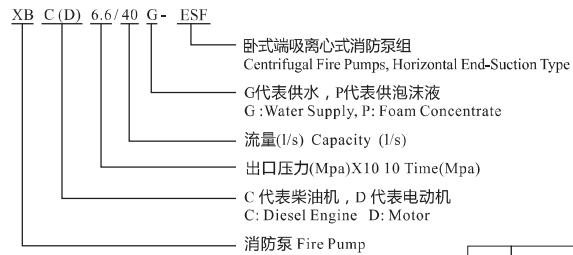

结构图 Structure Design

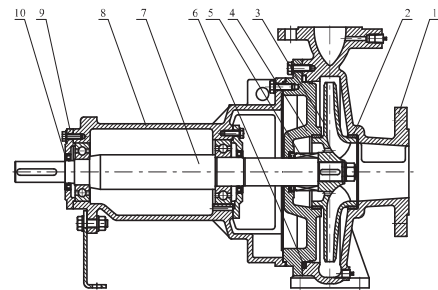

序号 NO	零件名称 Part Name	材料 Material
1	泵体 Pump Casing	球墨铸铁QT500-7 Ductile Cast Iron QT500-7
2	耐磨环 Wear ring	不锈钢304或青铜 Stainless Steel 304 or Bronze
3	叶轮 Impeller	304、316、2205、青铜 304、316、2205、Bronze
4	泵盖 Upper Casing	球墨铸铁 QT500-7 Ductile Cast Iron QT500-7
5	填料密封/机械密封 Packing Seal/ Mechanical Seal	碳纤维/石墨-碳化硅 Carbon-fiber/ Graphite-silicon carbide
6	O形橡胶圈 O-ring	橡胶圈 Rubber
7	泵轴 Shaft	20Cr13
8	悬架体 Suspension Body	铸铁HT200 Cast Iron HT200
9	轴承压盖 Bearing Cover	铸铁 Cast Iron HT200
10	油封 Oil seal	橡胶圈 Rubber

卧式端吸离心式消防泵组
Centrifugal Fire Pumps, Horizontal End-Suction Type

端吸泵系列性能范围 (50Hz)
PERFORMANCE RANGE OF NM FIRE PUMP-END SUCTION(50Hz)

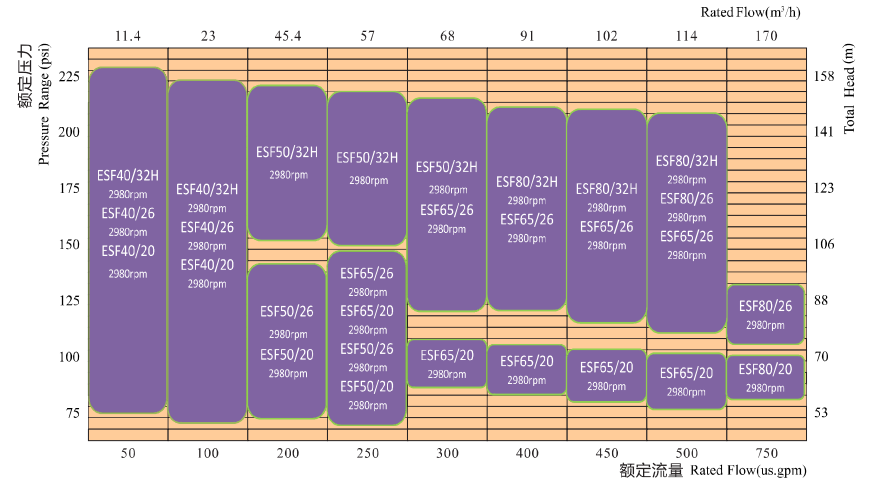

端吸泵系列性能范围 (60Hz)
PERFORMANCE RANGE OF NM FIRE PUMP-END SUCTION(60Hz)

